

AE-PDV21-2

Priority Demand Valve 2 1/2" - 4"



Key Features:

- Flow & level switch Input to activate PDV
- Failsafe will close PDV in event of power cut
- Manual reset button to ensure system checked after activation
- If the system fault remains unresolved after manual reset then the PDV will activate again to prevent reset when not safe
- Time delay function to prevent false activation without the need for expensive time delay flow switch
- Internal sounder beacon to alert on activation
- Volt free contact can be used as a fire output with activation solely by signal from the flow switch.

Application Engineering's BS 9251:2021 compliant priority demand valve assembly is for use upon activation of a flow or level switch, whereupon the valve will automatically close the domestic water supply allowing all water to divert to the sprinkler system.

The priority demand valve is available in various sizes and comes with either an actuated ball valve (sizes 1/2" - 2") or butterfly valve with an electric actuator (sizes 2 1/2" - 8") along with a 230v Relay box.

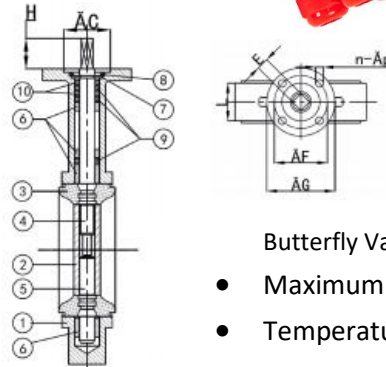
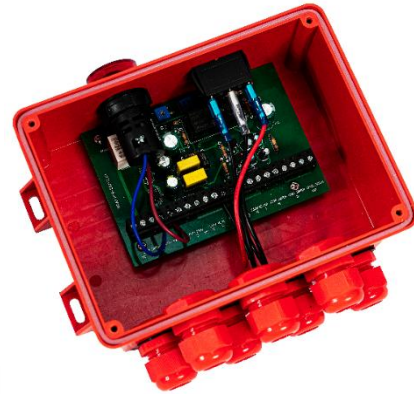

Butterfly Valve Technical data:

- Maximum Pressure 16 Bar Working
- Temperature -10°C to +110°C

N.	Part Name	Material
1	Body	Ductile Iron GGG40
2	Disc	Stainless Steel 316
3	Seat	WRAS EPDM
4	Upper Shaft	Stainless Steel 420
5	Lower Shaft	Stainless Steel 420
6	Bushing	PTFE
7	Split Pin	Spring Steel 65Mn
8	Circlip	Spring Steel 65Mn
9	O-ring	WRAS EPDM
10	Ring	Nylon 6 PA6
11	Lever	DN50-150 Aluminium DN200-300 D
12	Bolt	Stainless Steel 304
1	Body	Ductile Iron GGG40

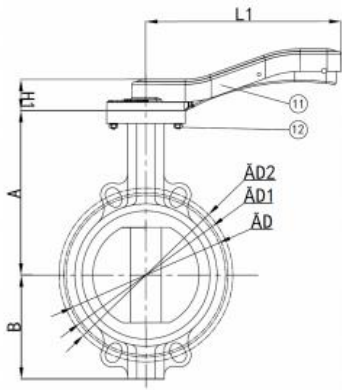

	50	65	80	100	125	150	200	250	300
A	142	154.5	161	180	193	205	250	282	326
B	60	70	85	104	120	135	171	205	248
D	125	145	160	180	210	240	295	350	400
D1	125	145	160	180	210	240	295	350	410
D2	120.7	139.7	152.4	190.5	215.9	241.3	298.5	361.9	431.8

How to Order

Port Size (G)	Part Number
2 1/2"	AE-PDV21-2-250
3"	AE-PDV21-2-300
4"	AE-PDV21-2-400
5"	AE-PDV21-2-500
6"	AE-PDV21-2-600
7"	AE-PDV21-2-700
8"	AE-PDV21-2-800

Wiring

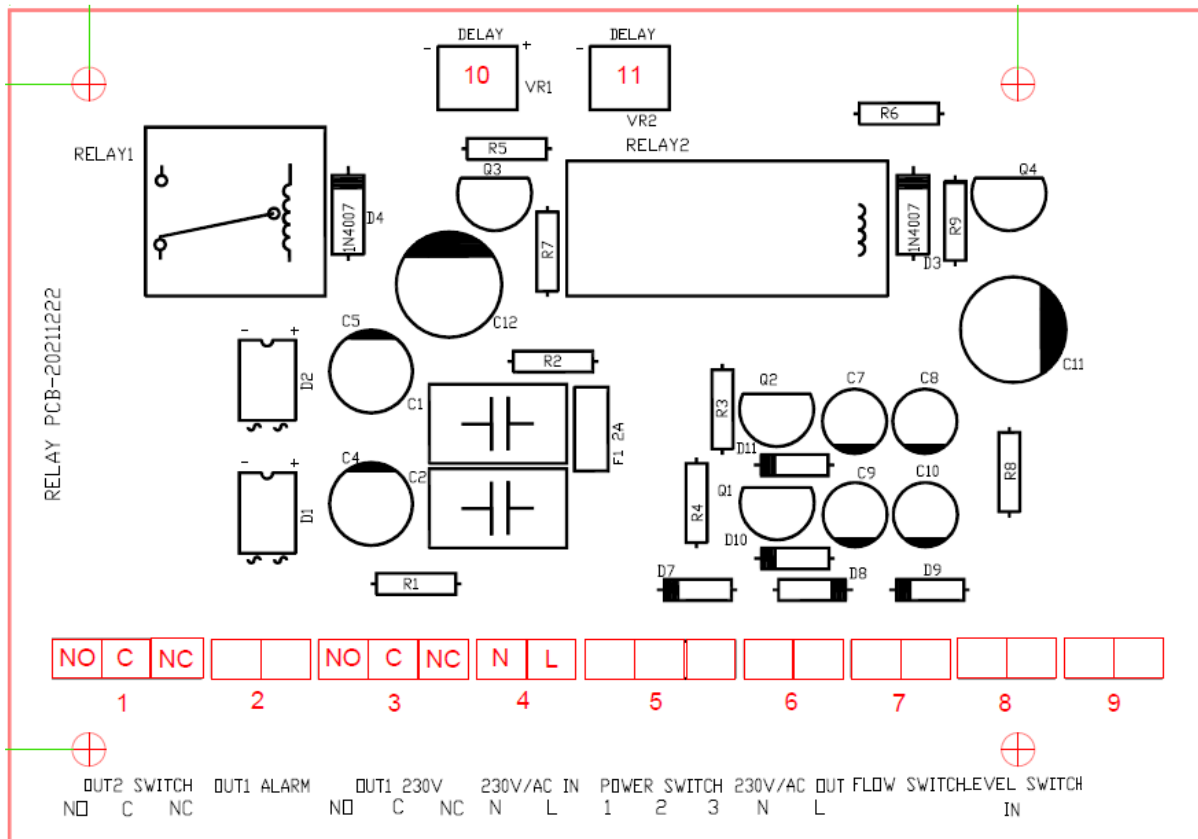

- | | |
|--|--|
| 1 - Volt free contact (for external alarm) | 7 - Flow Switch Input - Not Polarity Sensitive (NPS) |
| 2 - Pre-wired Output to sounder beacon | 8 - Level Switch Input (for low level) - NPS |
| 3 - Output to Actuator, use 'C' & 'NC' connections | 9 - Do not use for this application |
| 4 - 230v Mains Power in | 10 - Adjustable Time Delay 1 |
| 5 - Pre-wired output to Reset Button | 11 - Adjustable Time Delay 2 |
| 6 - Do not use for this application | |

*Turn clockwise to increase time delay, each delay controls a separate relay so both need adjusting

The actuator comes pre-wired with a 2 core cable, there is no need to go inside the actuator, this 2 core cable just needs to be wired into OUT1 230V in the relay, 'C' & 'NC' connections.

Wiring Notes

- OUT1 230V is a powered output, so for use as a 2021 PDV, all that is needed is to take the pre-wired FP200 two wires from the actuator, one to the "C" and one to the "NC" in relay box OUT1 230V, which is not polarity sensitive. There is no need to go into the actuator.
- The FLOW SWITCH & LEVEL SWITCH inputs are volt free normally open inputs, all they are looking for is a closed signal on activation of the switches

Installation Notes

- We advise that that a small bore bypass valve is fitted in parallel to the PDV so that if power should fail, a small amount of water can be provided to the building for drinking/ toilet flushing, this valve should be closed during normal operation
- On activation of either the flow or level switch the sounder beacon will activate and the valve will close. A manual reset is required to turn off the sounder beacon and reopen the valve, this is carried out by turning the power switch off and on again. If the fault has not been fixed then the alarm will sound again and another manual reset will be required
- The OUT1 SWITCH is a volt free output that will only activate in the result of a signal from the flow switch and can therefore be used as a fire output. This output will stop alarming once the flow switch stops activating, however, a manual reset is still required to return the PDV to a working state